

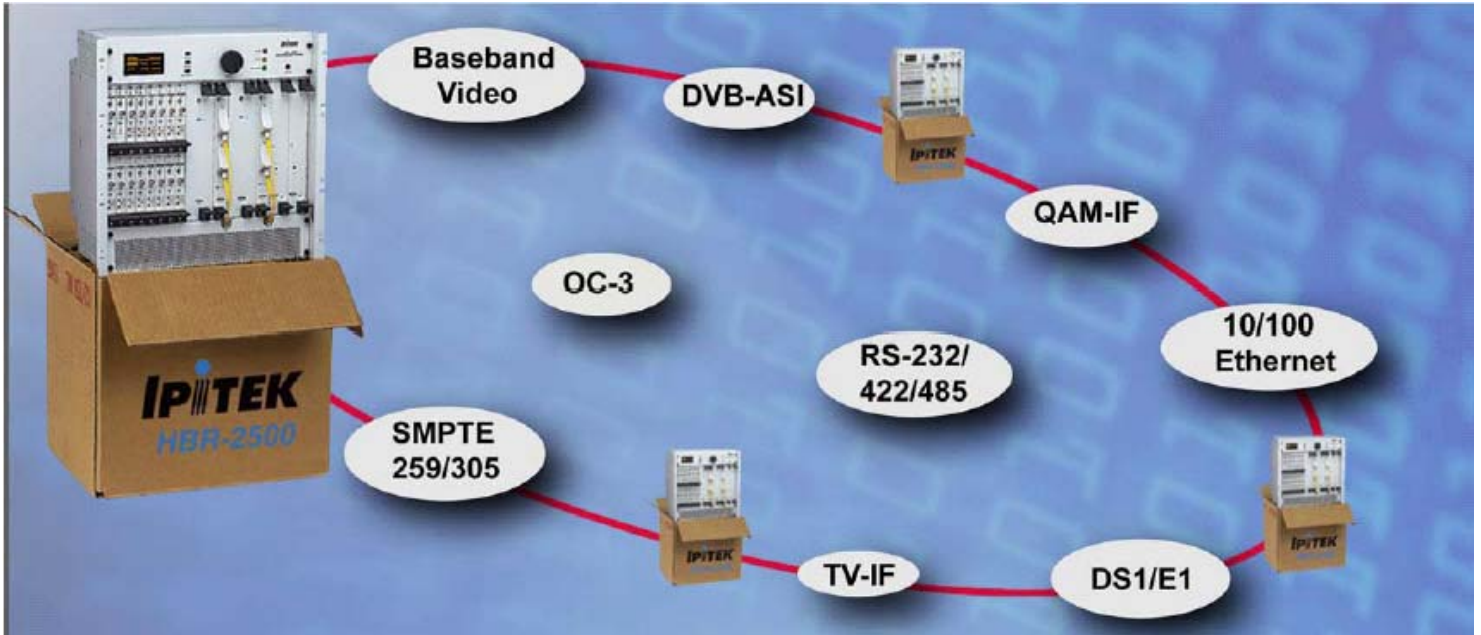

IPITEK Product News

IMTRAN Digital Transport Systems Issue II

HBR-2502 Digital Transport - Out of the Box & Into the Network



TAKE IPITEK'S HBR-2502 DIGITAL TRANSPORT OUT OF THE SHIPPING CARTON AND START NETWORKING!

HBR-2502 carries a wide variety of audio/video, DTV and digital signals meeting the distribution requirements of today's broadband systems.

Broadband systems today have constantly expanding requirements to transport more types of digital signals. So the efficient digital transport for today's needs literally has to be a high performance network device. Clearly, today's system isn't just for video and audio.

Responding to expanding industry requirements, IPITEK's HBR-2502 Digital Transport Platform offers the ideal solution for digital network interconnect for a very wide variety of traffic. IPITEK's HBR-2502 Digital Transport Platform offers loads of features designed to provide the most efficient transport of network signals. HBR uses the most advanced method of bandwidth assignment in the industry,

which means HBR users can move more traffic more efficiently in the same 2.5 Gb/s bandwidth as compared to other systems.

The HBR system also includes the capability to transmit and receive within the same unit, resulting in opportunities to move all types of signals from one location to another. Applications include returning satellite received signals from a dish farm to the headend via the nearest local hub, returning access signals from local hubs to a regional headend for redistribution, carrying digital video signals, video-on-demand signals and all types of simple or complex data information between headend and hub locations.

The HBR-2502 virtual cross connect system allows signals to be remapped to meet differing requirements at each location in the network. Signals may be added, dropped, passed or dropped and passed at each location in the network. In advanced networks, signals may be added at any location and dropped at any other location, resulting in highly flexible operations. With its flexible programming, HBR2502 operations are easily managed and programmed through the local node controller or through IPITEK's NodeWizard[®] Network Management System.

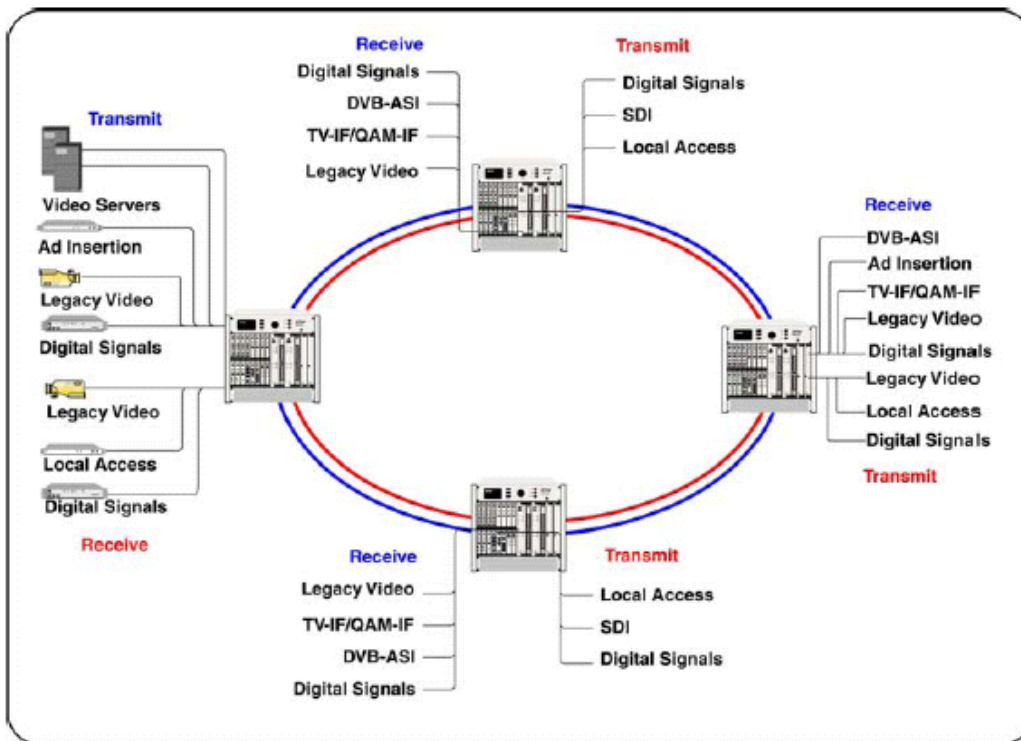

Typical HBR-2502 Network

HBR-2502 provides solutions for transport of any of these signals

Video

**Baseband Video and Audio
TV-IF
QAM-IF
DVB-ASI
SMPTE 259 SDI & 305 HDTV**

Digital

**10/100 Ethernet
DS-1/DS-3
OC-1/OC-3
RS-232/422/485**

The HBR-2502 supports all types of optical transmission, offering a choice of 1310nm, standard 1550 nm. or 1550nm CWDM and DWDM transmitters and choice of PIN or APD receivers for maximum distance.

The system can operate in virtually any legacy network topology, including unidirectional or bi-directional point-to-point, point-to-multipoint, typical star architectures, single or redundant rings, or counter rotating rings. Rings may be operated over separate fibers or a over common fiber utilizing WDM. A wide selection of power options assures operation over distance.

The HBR system can be equipped with ITU Grid lasers and is easily integrated into simple or complex DWDM systems. Typical systems can multiplex up to 20 Gb/s of information over an 8 HBR DWDM system. Standard systems operate over typical distances 80 Km without optical amplification. ITU lasers for operations up to 300 Km are also options for the HBR system.

In addition, the HBR system can be deployed as a metro backbone or metro access network, where the system is used as an edge aggregation device for a SONET ring. Operating at OC-48c, HBR easily integrates into an OC-192 network. The HBR enters the SONET network through an optical add/drop multiplexer and signals from the various HBR locations in the OC-192 network are transmitted to any other HBR location. Since the network is a ring, two way data signals are easily accommodated. 1+1 Terminal common equipment protection is also supported by the HBR system.

HBR-2502 system flexibility is unsurpassed. As new services are added or operating requirements change, the HBR system allows for easy reconfiguration and updating. The HBR operating system can be updated without any down time.

Additional Information about any of the data modules is found on the IPITEK web site or is available from IPITEK.

For additional product or ordering information related to the featured products or any of IPITEK's family of transmission products, visit our web site www.ipitek.com or send a message to sales@ipitek.com.



2330 Faraday Avenue Carlsbad, CA 92008 USA
Phone: Toll Free 888-447-4835; (01) 760-438-1010
Fax: (01) 760-438-2412